

Owner's Manual

We highly recommend you follow along with this video tutorial to assemble your eBike. Simply scan the QR code below.



Or visit:
velotricbike.info/S1

Table of Contents

QUICK START GUIDE	07
What's in the Box	08
Assembly and Installation	10
Tire Pressure Check	19
Battery & Charging	20
Indicator Status	23
Features and Test	24
Connect to Velotric App	27
Connect to Find My	28
eBike Diagram	30
Display Interface	32
Remote Diagram	33
BEFORE YOUR RIDE	35
Safety Check	36
Standover Height	36
Helmets	37
Chain Inspection	37
Electrical System Inspection	37
Brake System Inspection & Adjustment	39
DISPLAY	41
Remote Diagram	42
Display Interface	43
MENU Setting	47

FIND MY	55
How to Connect My eBike	56
How to Enable Lost Mode	58
How to Disable Lost Mode	60
How to Remove My eBike	62
How to Restore Factory Setting	64
OPERATION INSTRUCTION	65
Power, Throttle & Pedal Assist	66
Throttle on Demand	67
USE CONDITIONS	69
Wet Weather	70
Low-visibility Conditions	70
Weight Limits	71
Safety Guidelines	71
TROUBLESHOOTING	75
Troubleshooting	76
eBike Error Code	79
Battery Error Code	80
STORAGE & MAINTENANCE	81
Maintenance	82
Recommended Service Schedule	83
Storage	85
Cleaning	87
Parking	88

SPECIFICATIONS	89
Electronic	90
Mechanical	91
Range/Speed/Weights	92
SUPPORT INFO	93
WARRANTY POLICY	95
Limited Warranty Terms	96
This Limited Warranty Does Not Cover	96

QUICK START GUIDE

What's in the Box	08
Assembly and Installation	10
Tire Pressure Check	19
Battery & Charging	20
Indicator Status	23
Features and Test	24
Connect to Velotric App	27
Connect to Find My eBike Diagram	28 30
Display Interface	32
Remote Diagram	33

What's in the Box

MANUAL & TOOLS

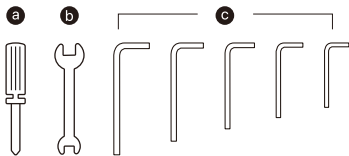

- a** Phillips Screwdriver
- b** 15mm/8mm Wrench
- c** 6mm/5mm/4mm/3mm/2.5mm Allen Key



Owner's Manual

PEDAL

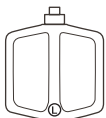

Left Pedal

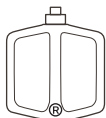

Right Pedal

What's in the Box

ACCESSORIES



Front Light

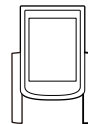

Display

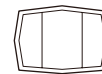

Front Reflector

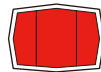

Rear Reflector

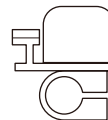

Bell



Cable Binder

CHARGER

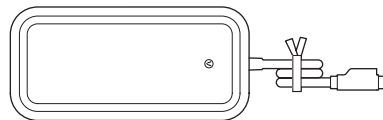

Charger

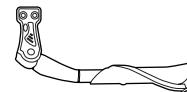

Kickstand

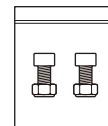

Bolt×2

Assembly and Installation

Kickstand/Front Wheel

1. Attach the kickstand and tighten the bolts.
2. Use a 6mm Allen key to loosen the axle rod.
3. Remove the plastic base of the front fork.

Note Make sure the brake rotor is aligned with the brake caliper pads, so the brake rotor can easily enter the caliper without any friction.

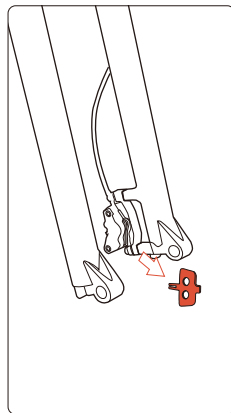
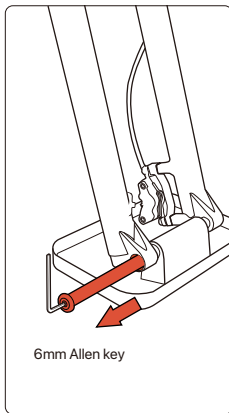
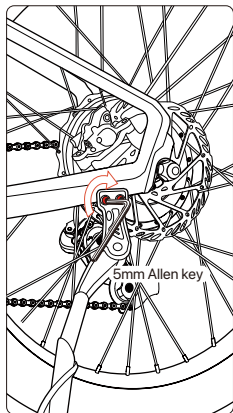

Front Wheel

Assembly and Installation

4. Lift the front of the eBike and insert the front wheel hub into the installation slot on the front fork. Ensure that the disc fits into the caliper with brake pads in the middle.
5. Align the mounting hole and insert the axle shaft. Confirm smooth threading, and then tighten it using a 6mm Allen key. Torque: 14 Nm.
6. Check and adjust the disc brakes to ensure they do not rub or produce any unusual sounds.

CAUTION Be careful not to accidentally squeeze the brake levers before the front wheel is installed. Otherwise, you may cause misalignment on your hydraulic brakes.

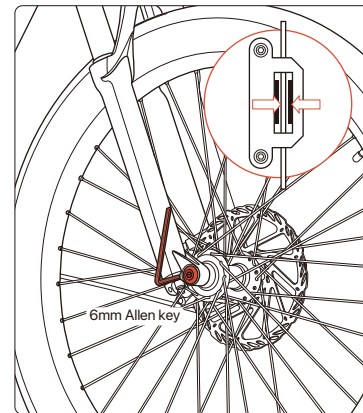
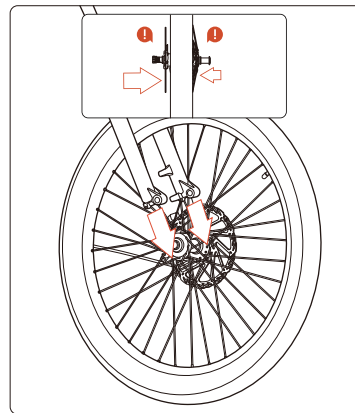

Assembly and Installation

Handlebar

1. Use a 4mm Allen key to remove the handlebar stem cap
2. Insert the handlebar into the stem and pre-lock it (ensure that the handlebar is securely in place without any play).
3. Adjust the handlebar to align with the crosshairs.

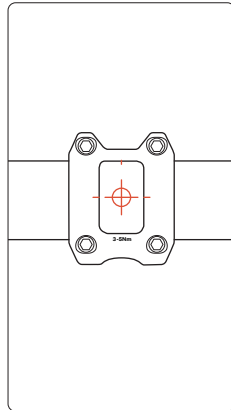
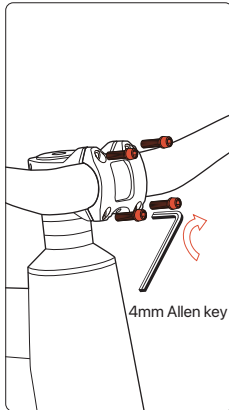
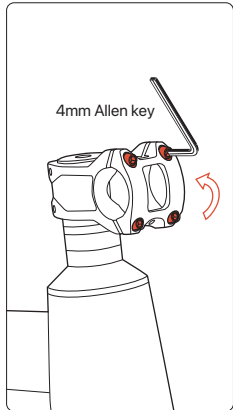

Handlebar

Assembly and Installation

4. Use a 4mm Allen key to tighten the handlebar stem cap in an X-pattern.
5. Adjust the stem to make the handlebar perpendicular to the front wheel.

▲ CAUTION Ensure even spacing above and below the stem cap. Torque: 6-8 Nm.

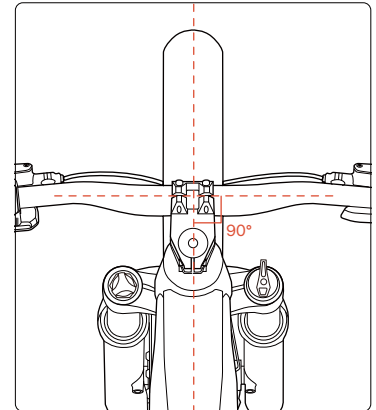
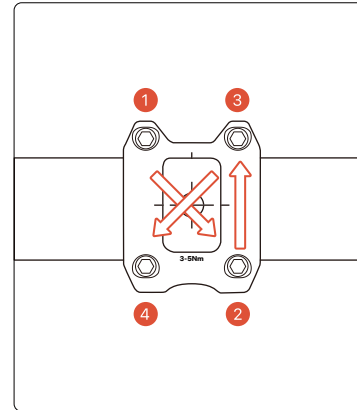

Assembly and Installation

Front Light

1. Align the front light bracket with the mounting port on the handlebar stem cap and securely fasten the screw. Torque range: 2.5~5.5 Nm.
2. Align the power cable with the arrow and connect it.
3. Use a screwdriver and an open-end wrench to tighten the nut. Torque range: 2.5~5.5 Nm.

Note Before traveling at night, please check the front light to ensure it functions properly.

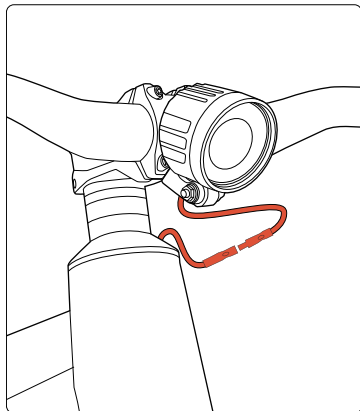
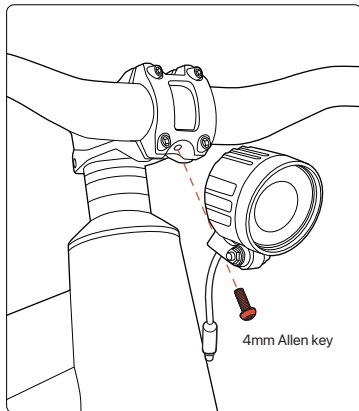

Display

Assembly and Installation

1. Use a 2.5mm Allen key to remove the instrument panel screws and attach it to the handlebar.
2. Pre-lock the screws on the tightening ring.
3. After adjusting the angle, use the Allen Allen key to tighten the screws.
4. Find the corresponding color-coded plug and connect the wires.
5. Use the cable binder to secure the instrument panel and front light wires.

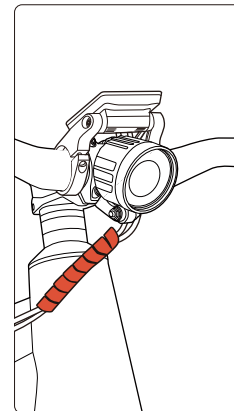
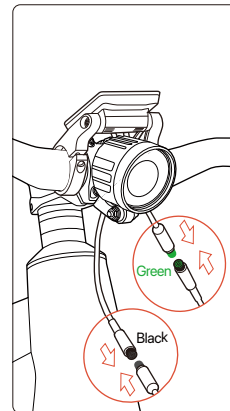
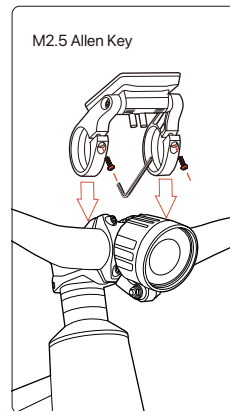

Assembly and Installation

Bell and Front/Rear Reflector

1. Use a Phillips screwdriver to remove the screws from the bell. Then slide the bell onto the right side of the handlebar and adjust the angle and tighten using a screwdriver.
2. Use a Phillips screwdriver to sequentially remove the screws from the front and rear reflectors and set them aside.
3. Place the gasket inside the mounting ring of the front reflector and slide it onto the handlebar. Adjust the angle (perpendicular to the ground at a 90° angle) and tighten using a screwdriver.

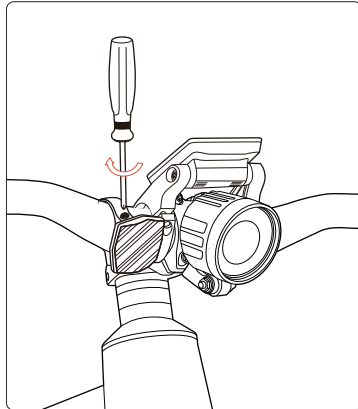
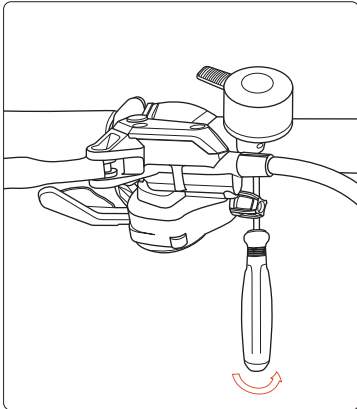

Bell and Front/Rear Reflector

Assembly and Installation

4. Slide the mounting ring of the rear reflector onto the seatpost (position it between 30-50mm from the top)
5. Ensure it is not obstructed and ensure the reflector is vertical to the ground.

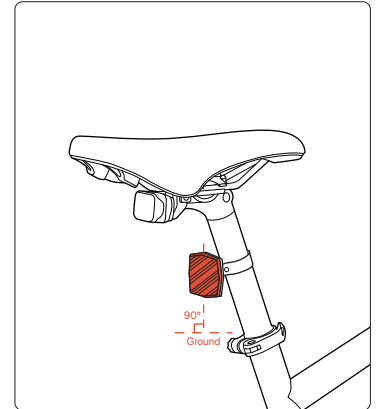
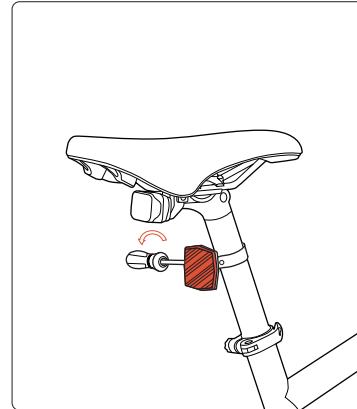

Assembly and Installation

Pedals

1. Identify each pedal by the sticker on the pedal axle: "L" indicates the left pedal and "R" indicates the right pedal.
2. Install the right pedal. Carefully thread in the right pedal by hand, turning clockwise, as shown in the illustration below.
3. Tighten the right pedal securely with a 15mm wrench.
4. Install the left pedal. Carefully thread in the left pedal by hand, turning counter-clockwise, as shown in the illustration below.
5. Tighten the left pedal securely with a 15mm wrench. Torque range: 35 Nm to 40 Nm

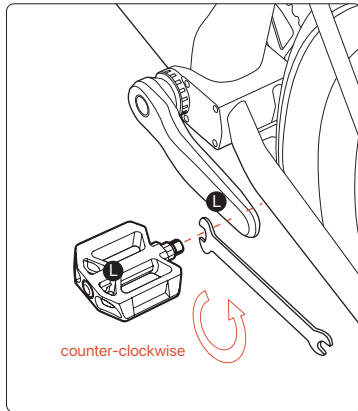
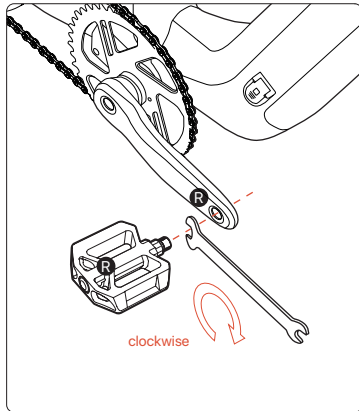

Tire Pressure Check

1. Check tire pressure by hand, and if it's easily compressible, it indicates low pressure and needs inflation.
2. Use an inflation pump equipped with an AV interface.
3. Inflate the tire until it is no longer easily compressible (do not exceed the tire's maximum recommended pressure).
4. Follow the tire markings for the maximum recommended pressure.

Note Check tire pressure before every ride.

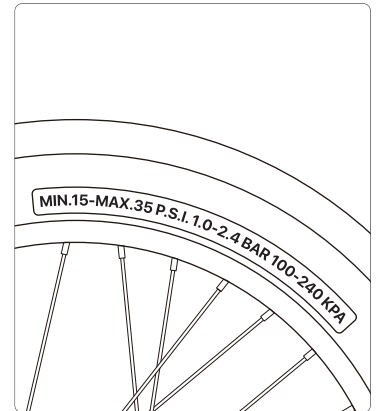
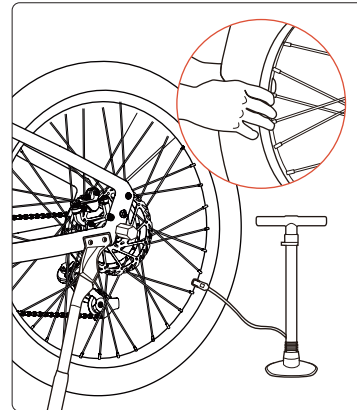

Battery & Charging

Activate Battery

Method A

1. Make sure the battery is securely installed.
2. Charge the eBike for over 5 seconds to activate the battery.

Method B

1. Remove the battery: Disconnect the charger, turn the key, then remove the battery.
2. Activate the battery: Press and hold the battery power button for 5 seconds. When the battery indicator lights up, it indicates that the battery is activated.
3. Reinstall the battery: Align the battery with the battery compartment and slide it in. Press the battery with your hand until you hear a clicking sound.

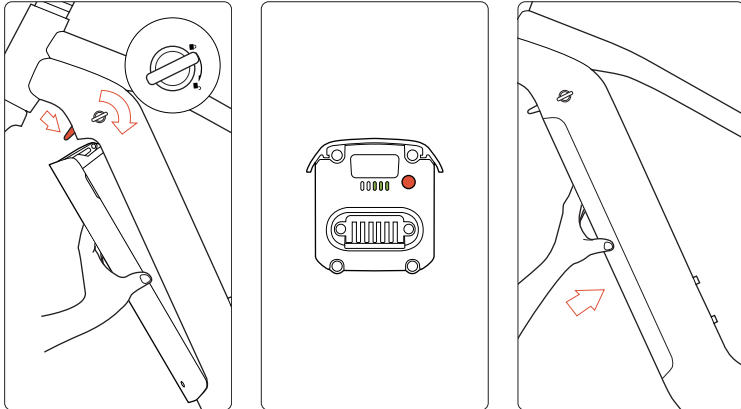

Charge the Battery

Battery & Charging

The battery can be charged either in or out of the eBike.

A. Charging on the eBike:

1. Power off the eBike before charging the battery in the eBike.
2. Insert the charging cable plug into the eBike's charging port. The LED indicator will turn red, and the screen will display that the vehicle is in charging mode.
3. The indicator will turn green when the battery is fully charged. Unplug the charger first before pulling out the cord from the battery.

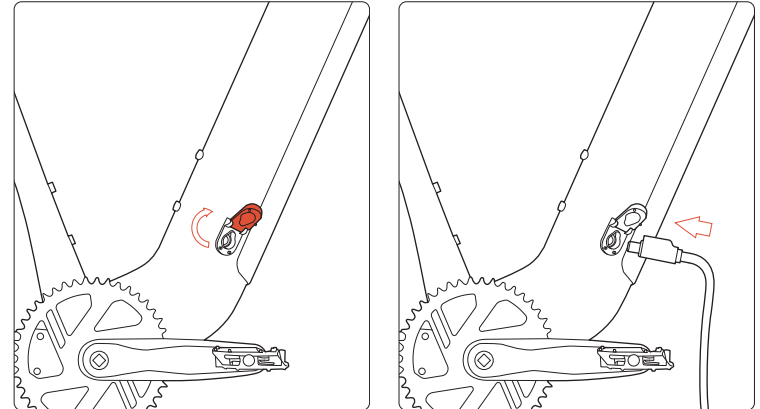

Battery & Charging

Charge the battery

B. Removing the Battery for Charging:

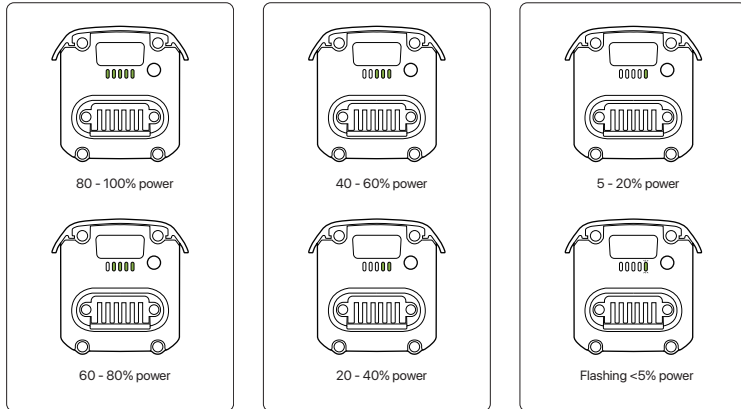

1. Make sure the battery is placed on a flat and clear surface. Plug the DC charging cable (barrel connector) into the port.
2. Plug in the charger, the LED indicator will turn red and the battery indicator will flash.
3. The indicator will turn solid green when the battery is fully charged, and the battery's charge indicator will blink.

- ▲ WARNING** 1. Charge the battery in an environment from 50–86°F (10–30°C).
2. The battery won't charge when it is over 113°F (45°C) or below 32°F (0°C). Let the battery adjust to room temperature for at least 1 hour before trying again.

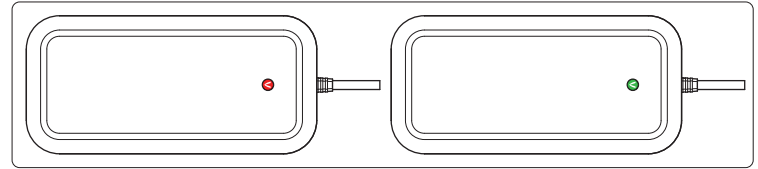

Indicator Status





Color	Indicator Status	Description
Red	Solid on 	The battery is charging
Green	Solid on 	The battery is fully charged

Note While charging, the charger indicator turns solid red from green and turns solid green when the battery is fully charged.

▲ CAUTION The indicator on the charger can be illuminated by pressing the indicator button on the top of the battery when the battery is not charged.

Features and Test

1. Please scan the QR code to find warranty information. Then peel the protective film off the display.
2. Long press the  button for 2 seconds to turn power on.
3. Single press the  or  button to increase/decrease the assist level.

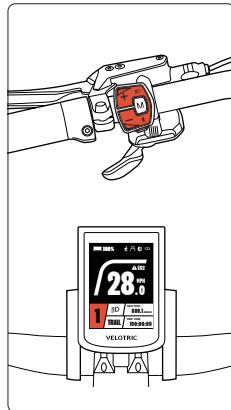
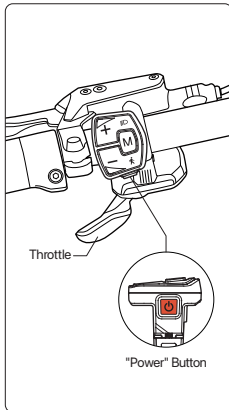
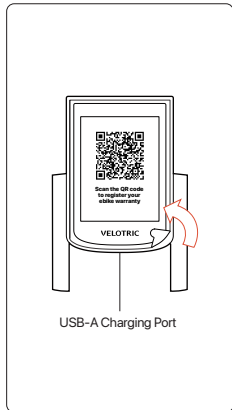

Features and Test

4. Long press the  button for 2 seconds to turn the front and rear lights on/off.

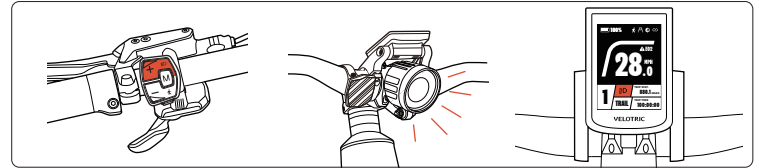

5. Press and hold the  button to active the Walk Model, release the button to turn off.

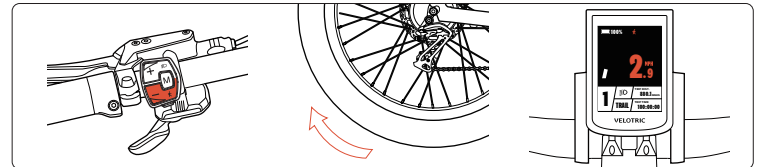

Features and Test

6. Single press the **M** button to switch riding data.
7. Long press the **M** button for 2 seconds to enter MENU.
8. Single press the **U** button to switch riding mode.

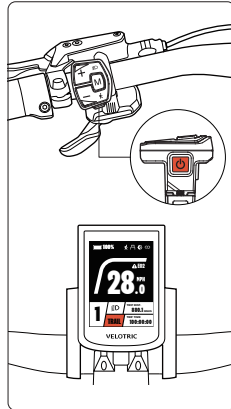
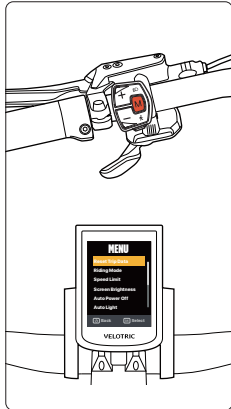
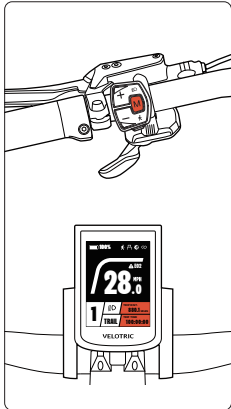

Connect to Velotric App

1. Long press the **M** button for 2 seconds to enter MENU.
2. Single press the **-** button to switch to "Connect to App". Then single press the **M** button.
3. Scan the QR-Code displayed on the screen with Velotric App to pair your eBike.

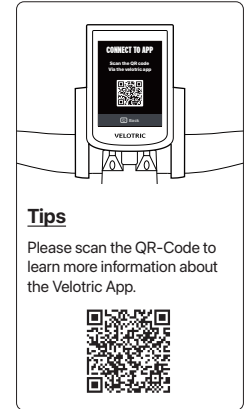
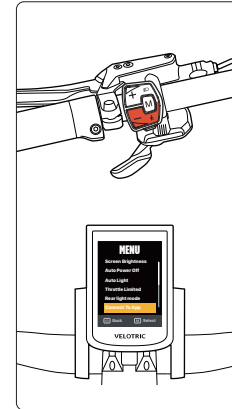
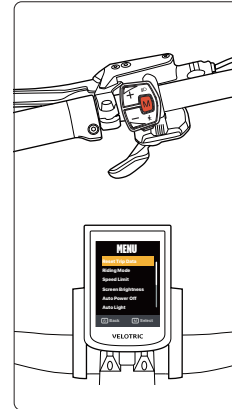

Tips

Please scan the QR-Code to learn more information about the Velotric App.



Connect to Find My

1. Long press the **M** button for 2 seconds to enter MENU.
2. Single press the **←** button to switch to "Find My". Then single press the **M** button to enter Find My settings.
3. Select "Find My" and single press the **M** button. Once the eBike emits a sound, it is now ready to be paired.

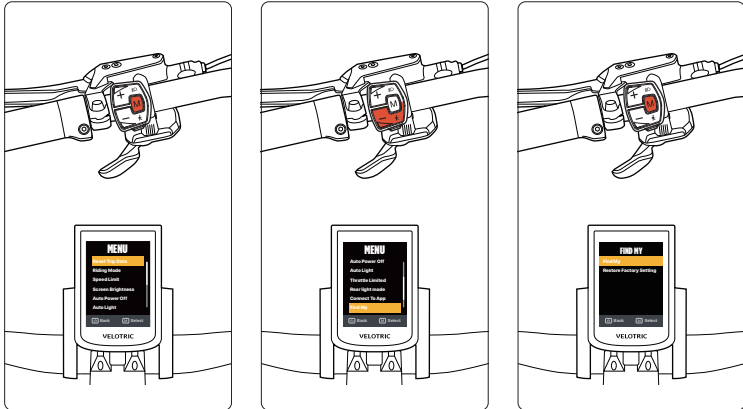

Connect to Find My

4. Open the Find My app on your device. Under the "Items" section, tap "Add Item".
5. Tap "Other Supported Item".
6. When your eBike is detected, tap the "Connect" button. Follow the instructions within the Find My app to complete the pairing process.

Note Please complete the pairing within 5 minutes in the Find My app.

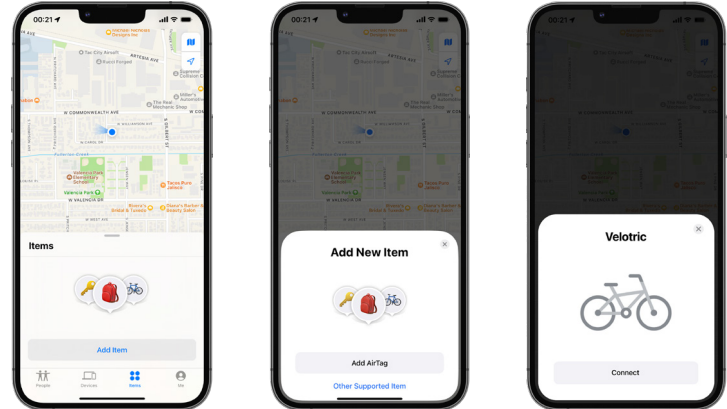

eBike Diagram

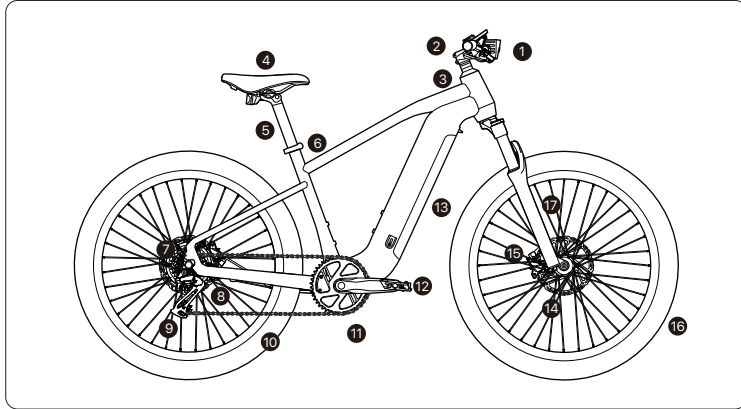

- | | | |
|------------------|-------------------|--------------------|
| 1 Front Light | 7 Motor | 13 Battery |
| 2 Handlebar | 8 Cassette | 14 Brake Rotor |
| 3 Stem | 9 Rear Derailleur | 15 Brake Caliper |
| 4 Saddle | 10 Chain | 16 Tire |
| 5 Seatpost | 11 Crankset | 17 Suspension Fork |
| 6 Seatpost Clamp | 12 Pedal | |

eBike Diagram

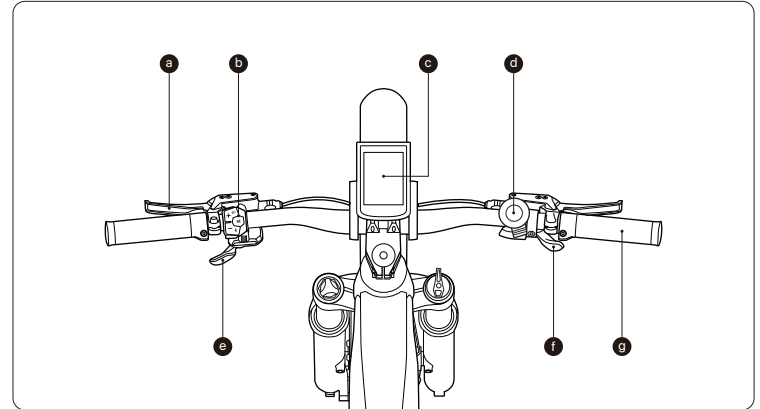

- | | |
|---------------|------------|
| a Brake Lever | e Throttle |
| b Remote | f Shifter |
| c Display | g Grip |
| d Bell | |

Display Interface

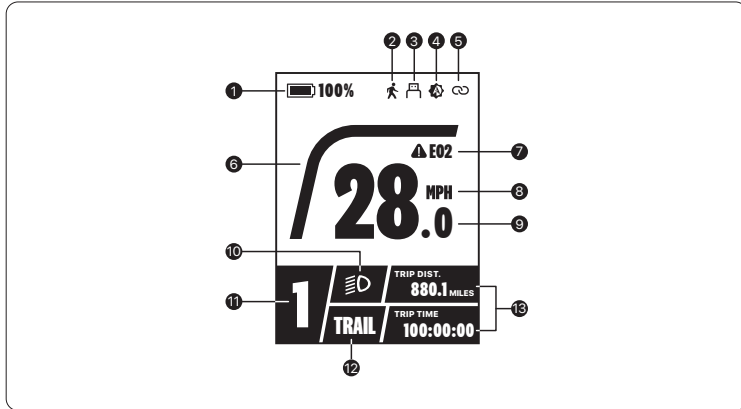

- | | | |
|-----------------------|-------------------|-----------------|
| 1 Battery Level | 6 Power Bar | 11 Assist Level |
| 2 Walk Mode | 7 Error Code | 12 Riding Mode |
| 3 USB Port Charge | 8 Speed Unit | 13 Riding Data |
| 4 Adaptive Brightness | 9 Real-time Speed | |
| 5 Phone Connection | 10 Light | |

Remote Diagram

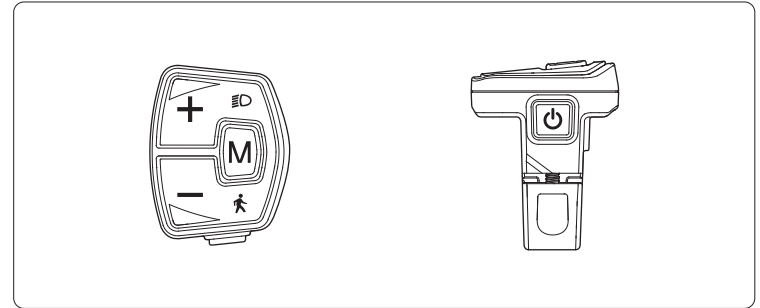

Long press for 2 seconds :

- Power on/off

Single press:

- Switch riding mode
- Return to previous page



Single press:

- Increase/decrease assist level



Long press for 2 seconds :

- Turn on/off front and rear lights



Long press for 2 seconds :

- Turn on walk mode, release to turn off



Single press:

- Switch riding data

Long press for 2 seconds :

- Enter MENU

BEFORE YOUR RIDE

Safety Check	36
Standover Height	36
Helmets	37
Chain Inspection	37
Electrical System Inspection	37
Brake System Inspection & Adjustment	39

Safety Check

- Ensure that the handlebar cables were routed correctly when the handlebar was installed. Turn the handlebar fully to the left and right and ensure that no cables or wires can be taut.
- Ensure that the pedals are secured with a pedal wrench according to the torque value listed in “Recommended Torque Values”.
- Ensure that the cable connectors on the ebike are all plugged in securely and that nothing loosened in shipping.
- Check the brake functions per the directions in the “Brake System Inspection”.

It is normal that brakes can rub a little the first few times you ride. Any squeaks or noises will disappear with use.

Standover Height

When selecting a new ebike, the correct choice of frame size is the most basic safety consideration.

Standover height is the basic element of ebike fitness. It is the distance from the ground to the top of the ebike frame at the point where your inseam is when straddling the ebike with both feet flat on the ground.

There should be a clearance of 1 inch to 2 inches (25.4 mm to 50.8 mm) between your crotch and the top tube of the ebike.

If your crotch touches the frame, it indicates that the ebike is too big for you.

To check for the correct standover height, straddle the ebike while wearing the kind of shoes in which you will be riding, and bounce vigorously on your heels.

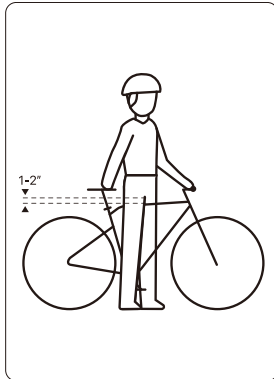

Helmets

Safety while cycling is of paramount importance. When riding a bicycle, always wear a properly fitting helmet and wear it correctly. Many places require the use of specific safety equipment. It is your responsibility to familiarize yourself with local laws, regulations, and ordinances in the area-in-which you're cycling and to comply with all applicable laws, including equipping yourself and your bicycle as required by law.

Chain Inspection

- Ensure the chain is clean, properly lubricated, and runs smoothly.
- Exercise extra caution when riding in wet, salty, corrosive, or dusty conditions.

Electrical System Inspection

Display

- Ensure that the cable of the display is properly connected and secured.
- Ensure that the display is securely attached, positioned, and functioning properly.

Motor Cutoff Function

Ensure that the throttle, brake levers, and motor are working properly and in good condition. The front and rear brake levers contain motor cutoff switches, which cut off power from the motor whenever the brakes are applied. When pushing the throttle to power the eBike forward and squeezing the left or right brake lever to engage the front or rear brake, the motor will immediately stop providing power assistance. If anything seems wrong, take your eBike to a qualified mechanic.

Front Light & Rear Light

- Ensure that the front and rear lights are securely attached and properly positioned.
- Ensure that the front and rear lights are not covered by foreign objects.
- Ensure that the cable of the front light is properly connected and secured.
- Ensure that the front light can be switched on or off when pressing the "Light" button.
- Ensure the rear light will illuminate a brighter, solid brake light when a brake lever is squeezed.

Battery

- Ensure that the battery is free from any visible damage including cracks, dents, deformation, and other abnormalities.
- Ensure that all connector contacts of the battery are clean, dry, and free of dirt and corrosion.
- Ensure that the battery is locked in the battery tray properly before use.
- Ensure that the battery is well charged before riding. You can check the charge level by pressing the button on the top of the battery to illuminate the charge level indicator. For more detailed information, refer to "Battery Indicator Status".
- Ensure that the battery is stored at an ambient temperature of 50°F to 77°F (10°C to 25°C). For more detailed information, refer to "Battery Storage".

Cables

- Ensure that all cables are not overly bent and no kinks are present.
- Check and ensure all cable connections are tight, secure and free from debris or moisture.
- Ensure that there is no damage or wear on the cables.
- Ensure that all cables and housings are properly secured to the frame or fork so that they cannot interfere with or get caught on moving parts.

Brake System Inspection & Adjustment

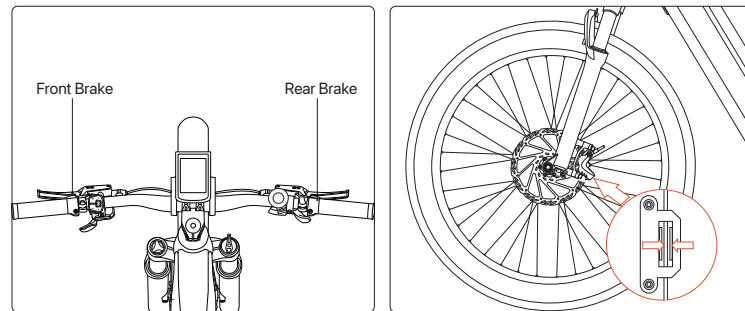

Brakes are essential to safety. Test your brakes for proper functionality before every ride.

- Ensure that the brakes are clean and free of debris that could interfere with the brake system.
- Ensure that brake levers are lubricated and tightly secured to the handlebar.
- Check brake pads and rotors for wear and make sure that they are not overworn.
- Ensure that the brake rotor fits correctly between the brake pads.
- Ensure that the front and rear brakes work properly.
- Test that the brake levers are firm and that the brake, motor cutoff switch, and rear light are functioning properly.
- While the eBike is stationary, make sure you can apply full braking force without the brake lever touching the handlebar. Otherwise, the brake lever needs to be adjusted. For detailed information, refer to "[Adjust the Brake Lever Positioning](#)".

Adjust the Brake Lever Positioning

Most riders would be comfortable with the default position of the brake levers. However, you may adjust them according to your preference and hand size.

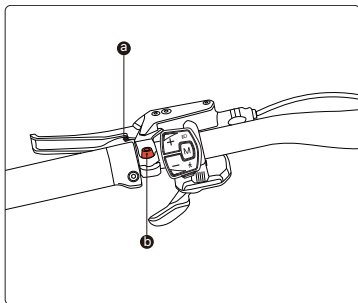

If you have big/small hands or find it difficult to squeeze the brake levers, you can also adjust the distance between the brake lever and the handlebar according to the steps below.

1. Locate the barrel adjuster (a).
2. Rotate the barrel adjuster counter-clockwise to move the brake lever closer to the handlebar, or rotate the barrel adjuster clockwise to move the brake lever away from the handlebar.

To adjust the angle of the brake lever, follow the steps below.

1. Loosen the brake lever clamp bolt (b) .
2. Adjust the angle of the brake lever.
3. Retighten the bolt of the brake lever clamp .

Note Ensure that the brake lever is parallel to the grip when a full brake is applied and you can hardly pull the lever closer to the grip.

DISPLAY

Remote Diagram	42
Display Interface	43
MENU Setting	47

Remote Diagram

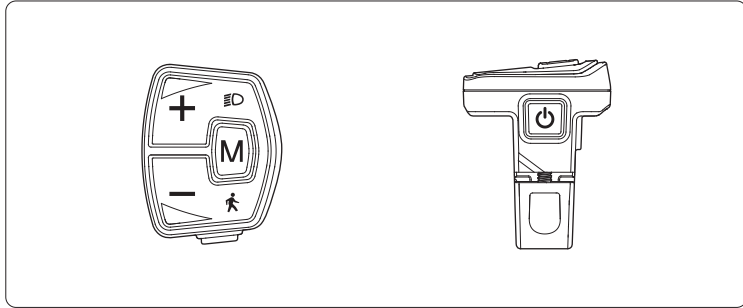

Long press for 2 seconds :

- Power on/off

Single press:

- Switch riding mode
- Return to previous page



Single press:

- Increase/decrease assist level



Long press for 2 seconds :

- Turn on/off front and rear lights



Long press for 2 seconds :

- Turn on walk mode, release to turn off



Single press:

- Switch riding data

Long press for 2 seconds :

- Enter MENU

Display Interface

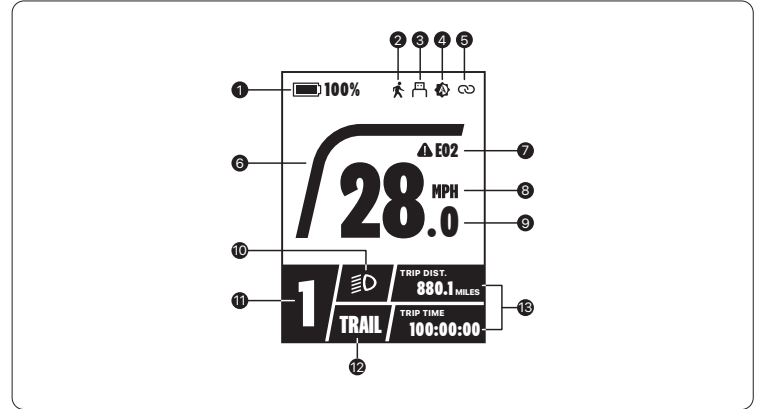

- | | | |
|-----------------------|-------------------|-----------------|
| 1 Battery Level | 6 Power Bar | 11 Assist Level |
| 2 Walk Mode | 7 Error Code | 12 Riding Mode |
| 3 USB Port Charge | 8 Speed Unit | 13 Riding Data |
| 4 Adaptive Brightness | 9 Real-time Speed | |
| 5 Phone Connection | 10 Light | |

Battery Indicator

The battery indicator can display two statuses. When the battery level is lower than 20%, the color will turn yellow to remind you to get the battery charged.

When the battery is depleted, the vehicle control system will activate the low-voltage protection mode, cutting off the vehicle's power output and displaying a 'Low Battery' alarm on the dashboard. Upon seeing the alarm, please connect the power supply to recharge the battery. Note that prolonged battery depletion can jeopardize the battery's lifespan.



Light

Long press the **+** button for 2 seconds to turn on/off the front and rear lights.

If the Auto Headlight is ON, the light icon will be displayed like the diagram:



Light on



Light off



Auto Light

Walk Mode

Press and hold the **-** button to activate the Walk Mode. Your eBike will travel at a constant speed of 2.9mph.

Release to turn off Walk mode. Interface shown as the diagram:

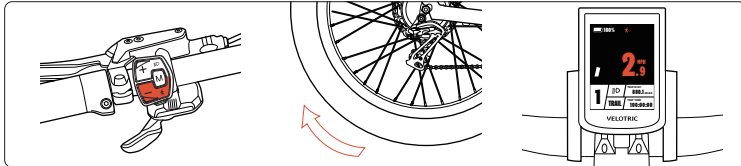

USB Port Charge

Your eBike can charge your other devices via the USB/Type-C charging port located in the back of the control panel.



Adaptive Brightness

By setting your screen brightness to "Auto," your display will automatically change its brightness level in relation to the amount of light in your immediate surroundings.

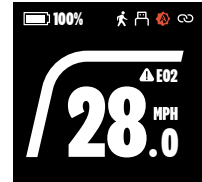

Phone Connection

Your eBike can be connected to the Velotric App via Phone Connection.

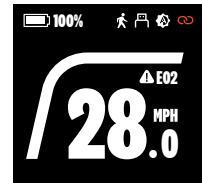

Riding Data

Single press the **[M]** button to cycle through various riding data:

- TRIP DIST. & TRIP TIME
- AVG SPEED & MAX SPEED
- CALORIES & CO₂ SAVED
- ODO & TOTAL TIME



Error Code

When the eBike electronic control system fails, the display will automatically indicate the error code. For the definition of detailed error codes, please refer to "eBike Error Code" and "Battery Error Code".

Note The error code will disappear when the error is solved.

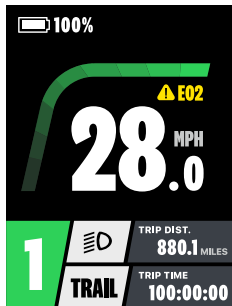

MENU Setting

When there is no speed in the power on state, long press the **[M]** button for 2 seconds to enter MENU.

Single press **[+]** or **[-]** button to select display settings.

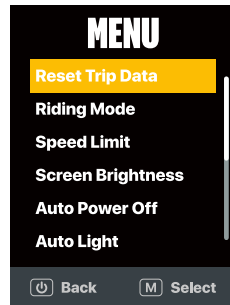

Reset Trip Data

1. Single press the **[M]** button to enter the setting page.
2. Single press the **[M]** button to reset the trip distance, trip time, average speed, max speed, calories burned and CO₂ saved.
3. Single press the **[Back]** button to exit without resetting.

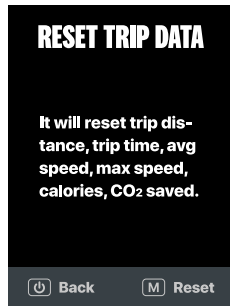

Riding Mode

Your eBike comes equipped with three different riding modes: ECO Mode, TRAIL Mode and BOOST Mode. Each mode will affect how much effort is needed in order to reach the top speed. By default we recommend ECO Mode as it strikes the balance between pedaling effort and electric assist. It is also the most battery-efficient mode.



ECO Mode: Our recommendation for paved roads. The most battery-efficient mode.

TRAIL Mode: Perfect for the off-road trails, gravel roads and adventure.

BOOST Mode: When you feel need for speed. Enjoy but stay safe.

How to Switch Riding Mode

1. Single press the **[M]** Button to enter the setting page.
2. Single press the **[+]** or **[-]** button to switch riding mode (ECO mode, TRAIL mode and BOOST mode). The default value is ECO mode.
3. Single press the **[M]** button to save the setting.
4. Single press the **[U]** button to exit without saving the setting.

Tips You can also single press the **[U]** button on the homepage to switch riding mode.

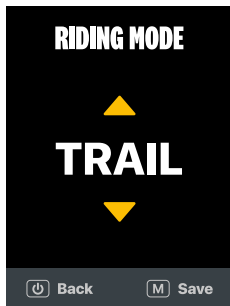

Speed Limit Setting

1. Single press the **[M]** Button to enter the setting page.
2. Single press the **[+]** or **[-]** button to adjust speed limit. The range of the maximum speed is 12mph-28mph. The default value is 20mph.
3. Single press the **[M]** button to save the setting.
4. Single press the **[U]** button to exit without saving the setting.

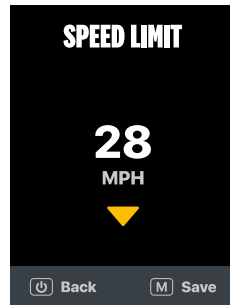

Screen Brightness Setting

1. Single press the **[M]** Button to enter the setting page.
2. Single press the **[+]** or **[-]** button to adjust screen brightness. The setting options are 1-5 and Auto. 1 is the darkest, 5 is the brightest, "Auto" means the display will detect the brightness automatically. The default value is 5.
3. Single press the **[M]** button to save the setting.
4. Single press the **[U]** button to exit without saving the setting.

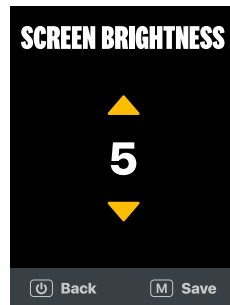

Auto Power Off Setting

1. Single press the **[M]** Button to enter the setting page.
2. Single press the **[+]** or **[-]** button to adjust the 'Auto Power Off' time. The setting options are 5, 10, 30, 60 minutes and OFF. The default value is 5 minutes. Your eBike will automatically power off itself after sitting idle for a few minutes. The OFF means the eBike will never power off itself automatically.
3. Single press the **[M]** button to save the setting.
4. Single press the **[U]** button to exit without saving the setting.

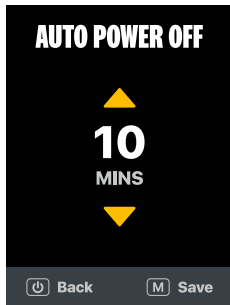

Note Your eBike won't power off itself automatically if it is in USB Port charging.

Auto Light Setting

1. Single press the **[M]** Button to enter the setting page.
2. Single press the **[+]** or **[-]** button to turn on/off Auto Light. The default value is ON. If it is ON, the front and rear lights will be turned on/off automatically when it detects the surrounding area is dark enough. It will also turn the front and rear lights off if it believes your surroundings are bright enough.

3. Single press the **[M]** button to save the setting.
4. Single press the **[U]** button to exit without saving the setting.

Note If you manually turn on/off the front and rear lights via the handlebar remote, the Auto Light will no longer automatically activate or deactivate the front and rear lights until the next time you power on the eBike. This is so that the ambient light sensor does not override your preferences.

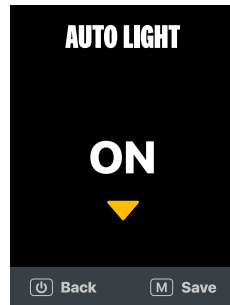

Throttle Limited Setting

1. Single press the **[M]** Button to enter the setting page.
2. Single press the **[+]** or **[-]** button to turn on/off Throttel Limited. The default value is ON. If it is ON, the top speed of throttle will be restricted by the top speed of each assist level. If it is OFF, the top speed of throttle will be always the speed you set up in the speed limit rather than restricted by the top speed of each assist level.
3. Single press the **[M]** button to save the setting.
4. Single press the **[U]** button to exit without saving the setting.

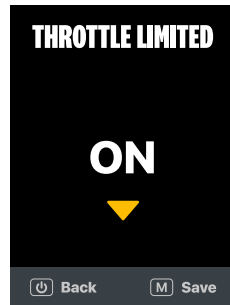

Rear Light Mode Setting

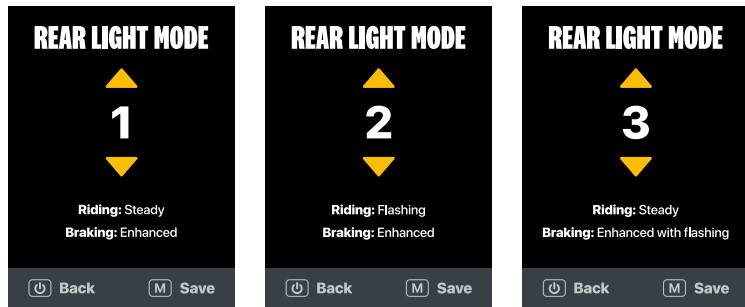

1. Single press the **[M]** Button to enter the setting page.
2. Single press the **[+]** or **[-]** button to switch rear light mode. The default value is 1. The setting options are 1, 2, 3.
Mode 1: The rear light is steady while riding and enhanced while braking.
Mode 2: The rear light flashes while riding and enhanced while braking.
Mode 3: The rear light is steady while riding and enhanced with flashing while braking.
3. Single press the **[M]** button to save the setting.
4. Single press the **[⏪]** button to exit without saving the setting.

Unit Setting

1. Single press the **[M]** Button to enter the setting page.
2. Single press the **[+]** or **[-]** button to switch unit. The setting options are mile and km. The default value is mile.
3. Single press the **[M]** button to save the setting.
4. Single press the **[⏪]** button to exit without saving the setting.

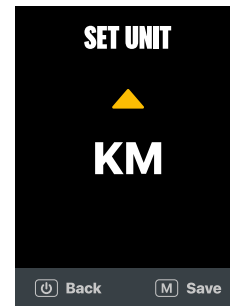

Version Info

- Single press the **[M]** Button to enter the setting page.
- This page will show the firmware version of display, controller, battery.
- Single press the **[⏪]** button to exit.

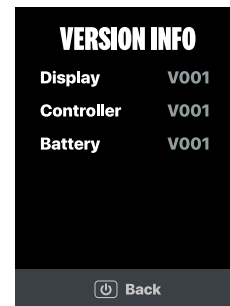

FIND MY

How to Connect My eBike	56
How to Enable Lost Mode	58
How to Disable Lost Mode	60
How to Remove My eBike	62
How to Restore Factory Setting	74

How to Connect My eBike

Follow these steps to pair your eBike with the Find My app.

1. Long press the **(U)** button for 2 seconds to power on.
2. Long press the **(M)** button for 2 seconds to enter MENU, select "Find My", then single press the **(M)** button.
3. Select "Find My", and single press the **(M)** button. Once the eBike emits a sound, it is now ready to be paired.

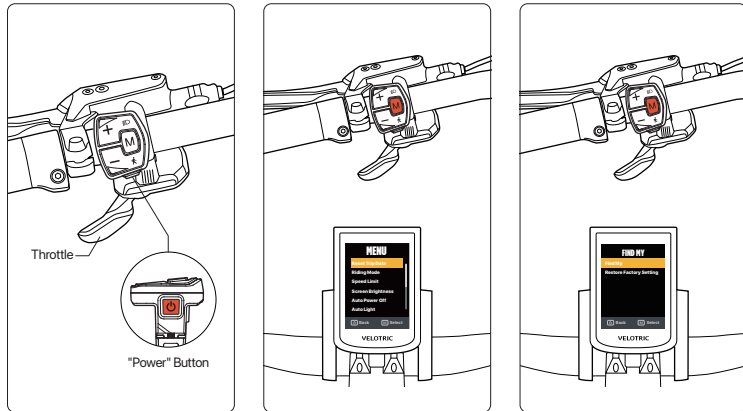

How to Connect My eBike

4. Open the Find My app on your device. Under the 'Items' section, tap [Add Item].
5. Tap [Other Supported Item].
6. When your eBike is detected, tap [Connect]. Follow instructions within the Find My app to complete the pairing process.

Note Please complete the pairing within 5 minutes in the Find My app.

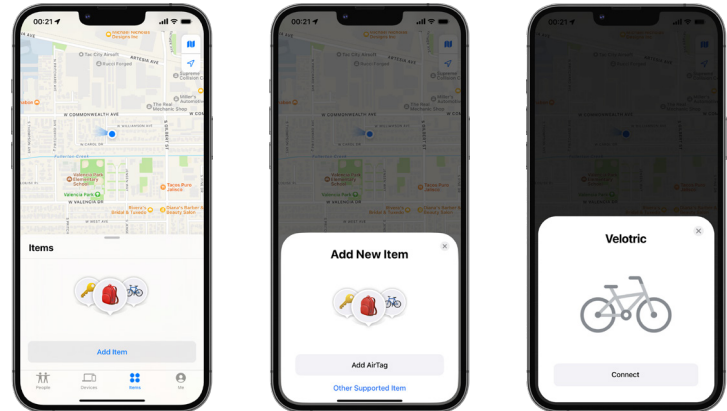

How to Enable Lost Mode

If your eBike is lost, please follow these steps to activate "Lost Mode" and locate your eBike.

1. Select your eBike from 'Items' list.
2. In Lost Mode, tap [Enable].

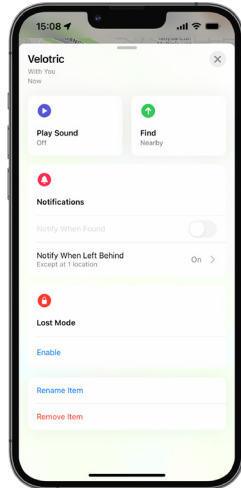
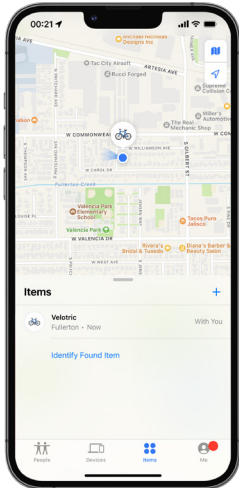

How to Enable Lost Mode

3. Read "WHAT WILL HAPPEN?" first, then tap [Continue].
4. Enter your phone number or email, then tap [Activate] to activate Lost Mode.

Note If your eBike is locatable, other users can tap [Identify Found Item] in the Find My app to help identify your eBike.

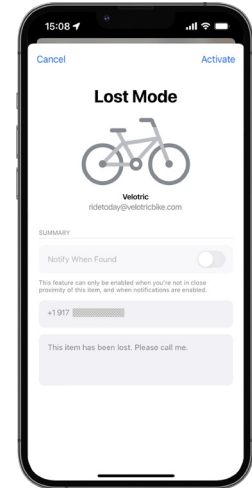
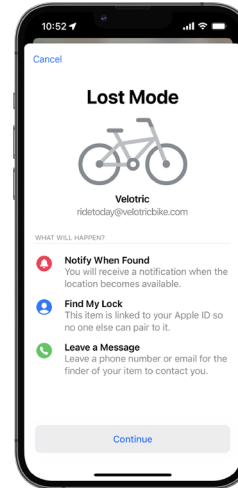

How to Disable Lost Mode

Once your eBike is found, follow these steps to turn off 'Lost Mode'.

1. Select your eBike from 'Items' list.
2. In Lost Mode, tap [Enabled].

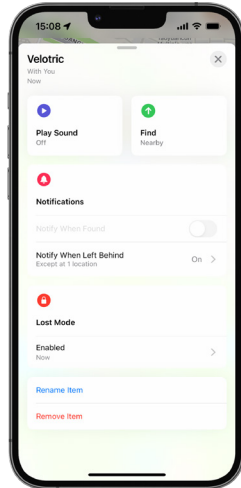
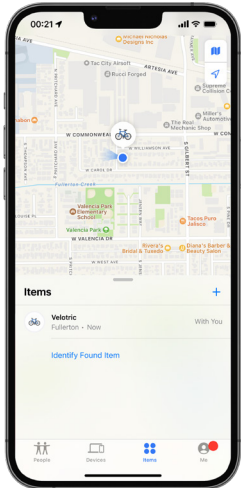

3. Tap [Turn Off Lost Mode]. You have now turned off Lost Mode.

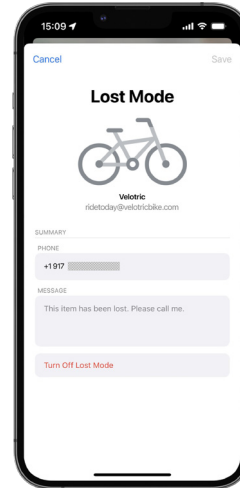

How to Disable Lost Mode

How to Remove My eBike

Follow these steps to remove your eBike from the 'Find My' network if you are no longer using this eBike.

1. Select your eBike from 'Items' list.
2. Scroll down to the bottom and tap [Remove Item].

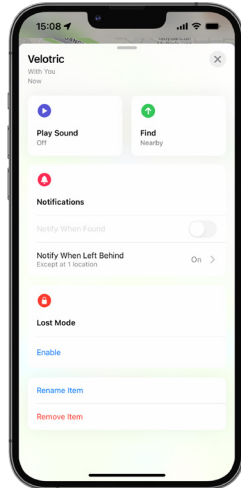
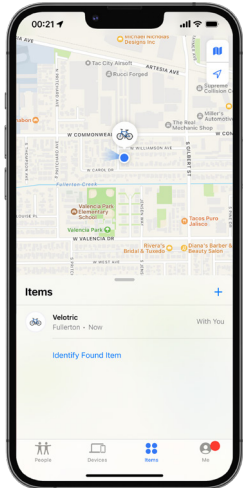

How to Remove My eBike

3. In the 'Remove Item' page, tap [Remove], and the eBike will be removed from your item list.

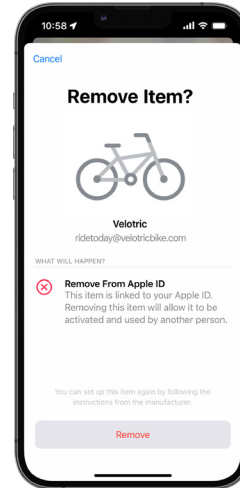

How to Restore Factory Setting

If the eBike is offline when removing from Find My app, restore factory setting will allow you to unpair the eBike.

1. Long press the **(P)** button for 2 seconds to power on. Long press the **(M)** button for 2 seconds to enter MENU. Select "Find My" and then single press the **(M)** button.
2. Select [Restore Factory Setting] and single press the **(M)** button. Next, select [Confirm] and single press the **(M)** button again. When you see the 'Success' prompt and hear the eBike emit a sound, the factory reset was successful.

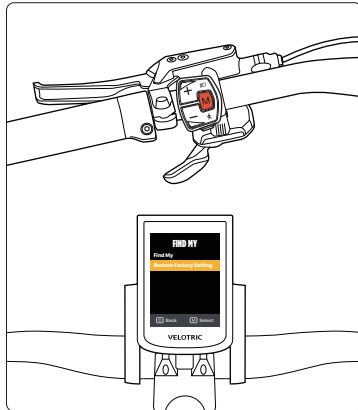
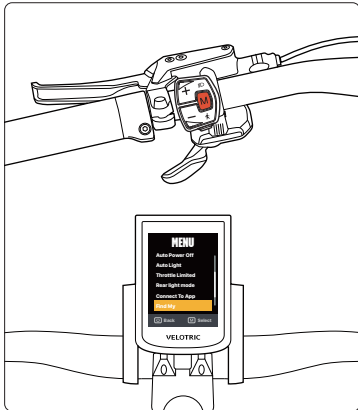

OPERATION INSTRUCTION

Power, Throttle & Pedal Assist
Throttle on Demand

66
67

Power, Throttle & Pedal Assist

Power On/Off

- Long press the  button for 2 seconds to power the eBike on or off.
- When powering on the eBike, the display and rear light will be illuminated automatically.
- The eBike will be powered off automatically after a few minutes of inactivity.

How the Throttle Works

You can push the throttle to propel the eBike forward without pedaling. If you release the throttle, the motor will stop supplying power as a backup.



Throttle on Demand

With throttle on demand, you can engage the bike's throttle even from a complete stop. This feature is designed to provide an extra boost when necessary, such as on steep hills or when approaching multiple stop signs. However, we highly recommend pedaling first and using the throttle as a secondary option to ensure stability and readiness.

How the Pedal Assist System Works

You can engage the PAS while pedaling, and it will call up assistance from the motor to help propel the eBike forward. If you stop pedaling, the motor will stop supplying power as a backup.

Select Appropriate Assist Level

You can adapt the power output according to your riding needs. When powering on the eBike, the assist level is "0" by default and there is no power assistance while engaging the throttle or pedaling. Once you begin riding, you can press the  or  button to select the appropriate assist level. When your riding speed reaches the speed limit for each level, the motor will no

longer provide power assistance. The power output and top speed of each level are shown in the table below.

Assist Level Description

Assist Level	Description
PAS 0	No power output.
PAS 1	Minimal power output for maximum battery efficiency.
PAS 2	Low power output for riding long distances.
PAS 3	Medium power output for city commuting.
PAS 4	Strong power output for active riding.
PAS 5	Maximum power output for extreme riding.
Walk mode	Small amount of power output for walking assistance.

- Note**
- When you try and engage the throttle and PAS at the same time, only the throttle works and there is no stacking power from the motor to propel the eBike forward.
 - When pushing the throttle to propel the eBike forward, squeeze the brake lever and the motor will stop providing power assistance.

Throttle on Demand

The throttle on demand feature allows you to apply throttle power when starting from a complete stop. This feature provides an extra boost when tackling steep hills, navigating multiple stop signs, and more. However, we highly recommend pedaling initially and using the throttle as a secondary option to ensure proper stability and readiness.

USE CONDITIONS

Wet Weather	70
Low-visibility Conditions	70
Weight Limits	71
Safety Guidelines	71

Wet Weather

Wet weather impairs traction, braking, and visibility, both for the cyclist and for other vehicles sharing the road. The risk of an accident is significantly increased in wet conditions. In wet weather, extra care is required when riding the eBike.

▲ WARNING Riding in wet conditions involves slippery hands, feet, and riding surfaces, which greatly increases your risk of accidents, serious injury, or death. Low-visibility conditions such as night, dusk, dawn, fog, mist, rain, or snow will compound the risk of injury or death.

If you must ride in wet conditions, taking the safety precautions below can reduce the risk to some extent.

- Stay alert. Ride defensively and expect the unexpected.
- Ride slower to better control the eBike in slippery conditions.
- Brake earlier as it will take longer to slow down than in dry conditions.
- Increase your visibility according to the safety precautions in [“Low-visibility Conditions”](#).

Low-visibility Conditions

Riding at night/dawn/dusk or in other low-visibility conditions such as fog, rain, mist and snow is dangerous. It is harder for a rider to read signs and identify and respond to hazards, and also harder for others to see and avoid you, increasing the risk of accidents, serious injury or death. Slippery and uneven surfaces will compound the risk. Avoid these conditions when possible. Should you have to ride in low-visibility conditions, taking the safety precautions below can reduce the risk to some extent.

- Ride slow.
- Stay alert. Ride defensively and expect the unexpected.
- Avoid dark areas and areas of heavy or fast-moving traffic.
- Wear reflective or light-colored clothing to get the attention of approaching motorists, pedestrians, and other traffic.

- If possible, ride on familiar routes.
- Ensure that the front and rear lights are functioning correctly and unobstructed.
- Ensure that the front and rear reflectors are correctly positioned and securely mounted, and are not blocked by any foreign objects.

Weight Limits

The total maximum weight limit or payload capacity of the eBike, including the weight of the eBike, rider, passenger, clothing, cargo, accessories, and so on, is 440 lbs (200 kg).

▲ WARNING Never exceed the weight limit of your eBike. Overloading may void the warranty and cause the eBike or eBike parts failure or loss of control, and result in serious injury or death.

Safety Guidelines

All users must thoroughly read and understand this manual before using their Velotric eBike. Additional manuals for components used on the eBike may also be provided and should be read before installing or using those components.

Ensure that you fully comprehend all instructions and adhere to all safety guidelines and warnings.

Safety Guidelines

The following safety guidelines provide additional information on safely operating your Velotric eBike and should be closely reviewed. Failure to adhere to these guidelines can result in serious injury or even fatalities.

Ensure that you fully comprehend all instructions and adhere to all safety guidelines and warnings.

You are responsible for familiarizing yourself with the laws and regulations governing the use of this product in your area.

Before Riding

Before your initial use, confirm that the eBike fits you properly. Riding an eBike that is either too large or too small may lead to a loss of control or falls.

Always wear an approved bicycle helmet while riding your eBike. Follow all helmet manufacturer instructions regarding fit and maintenance. Failure to wear a helmet when riding may result in severe injury or loss of life.

Before your first ride, ensure that your eBike is correctly assembled, tightened, and torqued to recommended specifications. Regularly inspect and maintain the condition of all components and hardware.

Verify that the handlebar grips are undamaged and securely installed. Loose or damaged grips can compromise your control and safety.

Off-road riding and EXTREME RIDING

Off-road riding demands close attention, specific skills, and involves variable conditions and hazards. Wear appropriate safety gear, and do not ride alone in remote areas. Check local rules and regulations regarding off-road eBike riding.

DO NOT ENGAGE IN EXTREME RIDING. This includes, but is not limited to, jumps, stunts, or riding that exceeds your abilities. Extreme riding is neither recommended nor permitted and may result in serious injury or death. Bikes and bike components have limitations in terms of strength and integrity, and engaging in extreme riding can damage bike components and lead to hazardous riding situations where you may be seriously injured or killed.

Note Neglecting to ensure proper installation, compatibility, correct operation, or maintenance of any component or accessory can result in severe injury or death.

Following any incident, consider your bike unsafe to ride until you consult with a certified, reputable eBike mechanic for a comprehensive inspection of all components, functions, and operations of the eBike.

▲ WARNING Failure to appropriately charge, store, or use your battery will void the warranty and may create a hazardous situation.

Prior to each ride, verify the operation of the brake motor cutoff switches. The brake system features an inhibitor that interrupts power to the electric motor when the brakes are applied. Confirm that the brake motor cutoff switches are functioning correctly before riding.

Exercise extreme caution when utilizing the pedal assistance and throttle features of this product. Understand and be prepared for the pedal assistance to activate as soon as you start pedaling.

Users must fully comprehend the operation of the thumb switch throttle and pedal assistance sensors before operating the bike. Exercise caution and travel at speeds appropriate for the area, riding conditions, and your experience level. Always start with the lowest assist level until you are comfortable with the bike and feel confident in controlling its power.

▲ WARNING Due to the increased weight and speed of electric bikes compared to regular bikes, extra care and attention are necessary while riding.

Exercise additional caution when riding in wet conditions, including reducing speed and increasing braking distances. Wet conditions can lead to slips and, consequently, severe injury or loss of life.

Disclaimer

Do not remove any reflectors.

Do not use this product with standard bike trailers, stands, vehicle racks, or accessories that Velotric has not tested for safety and compatibility and had not confirmed as safe and compatible with the bike.

Any modifications to your Velotric bike that have not been expressly approved by Velotric Bikes may void the warranty and result in an unsafe riding experience.

TROUBLESHOOTING

Troubleshooting	76
eBike Error Code	79
Battery Error Code	80

Troubleshooting

Problem	Most Common Solutions
---------	-----------------------

eBike does not work (No power):

Insufficient battery power	Charge the battery
Faulty connections	Clean and repair the connectors
Battery not fully seated in tray	Install the battery correctly
Improper turn on sequence	Turn on the ebike with proper sequence
Battery non-functional	Replace the battery

eBike rocks back and forth:

Wobbling fork	Adjust the fork or stem
Gap between stem and stem spacer	Close up the gap
Gap between lower end of head tube & suspension fork	Close up the gap

Irregular acceleration and/or reduced top speed:

Insufficient battery power	Charge or replace the battery
Loose or damaged throttle	Replace the throttle

Motor does not respond when the ebike is powered on:

Insufficient battery power	Charge the battery
Brakes are applied	Disengage the brakes
Throttle not reset	Reset or replace the throttle
Loose wiring	Reconnect or replace the wiring
Loose or damaged throttle	Tighten or replace the throttle
Loose or damaged motor plug wire	Secure or replace the wire

Damaged motor	Replace the motor
Damaged controller damaged	Replace the controller
Damaged PAS sensor	Replace the PAS sensor

Reduced range:

Low tire pressure	Inflate tires to PSI stamped on sidewall
Low battery	Charge the battery
Driving with too many hills, headwind, braking, or excessive load	Assist with pedals or adjust route
Battery discharged for long period without regular charges	Recharge the battery. If range decline persists, contact us through help@velotricbike.com
Brakes rubbing	Adjust the brakes
Faulty, damaged, or aged battery	Replace the battery

Battery will not charge:

Charger not well connected	Adjust the connections
Charger damaged	Replace the charger
Battery damaged	Replace the battery
Wiring damaged	Replace the wiring
Battery non-functional	Replace the battery
Battery overdischarged	Replace the battery
Ambient temperature below 41°F (5°C) or above 104°F (40°C)	Keep the battery in an environment with an ambient temperature of 50°F to 77°F (10°C to 25°C) for at least 1 hour

Wheel or motor makes strange noises:

Loose motor cable connection	Reconnect the cable
Damaged wheel spokes or rim	Repair or replace the spokes or rim

Damaged motor wiring	Replace the motor
----------------------	-------------------

Charger indicator flashes red while charging:

Charging abnormality	Unplug the charger and contact us through help@velotricbike.com .
----------------------	--

Display does not show speed or shows wrong speed:

Damaged wiring	Replace the wiring
Wrong wheel diameter settings	Initialize the settings
Damaged motor	Replace the motor
Mismatched tire	Replace the tire

Front/rear light cannot be illuminated:

Damaged light	Replace the light
Damaged controller	Replace the controller
Damaged Remote (PAS control panel)	Replace the remote (PAS control panel)

eBike cannot connect with device:

Damaged communication module	Replace communication module
Signal interference	Move your eBike

OR you can contact us through help@velotricbike.com and we will get you back as soon as possible.

eBike Error Code

Your Velotric eBike is equipped with an error detection system integrated into the display and controller. In the case of an electronic control system fault, an error code should display. If your ebike has an error code displayed at any time, it is recommended that you cease operation and contact us through help@velotricbike.com immediately. You can also scan the QR code to find more information about the error code.



Note The error code will disappear when the error is solved.



Battery Error Code

If your bike is unable to start or unable to charge, follow these steps to troubleshoot whether it is a battery failure.

Press the battery detection button, troubleshoot according to the following steps based on the LED light flashing mode.

Indicator Status	Description
	If the 2nd and 4th lights flashing with the 3rd light steady. Check the e-bike or charger for abnormalities.
	If the 1st and 5th lights are flashing with the 3rd light steady. Keep the battery in an environment with an ambient temperature of 50°F to 77°F (10°C to 25°C) for at least 1 hour.
	If all lights are flashing. The battery is faulty and can no longer be used.

STORAGE & MAINTENANCE

Maintenance	82
Recommended Service Schedule	83
Storage	85
Cleaning	87
Parking	88

Maintenance

Regular maintenance is important to your safety and the longevity of your eBike. Any part of a poorly maintained eBike can break or malfunction leading to an accident. Velotric strongly recommends that you follow a regular maintenance schedule based on normal use. If you ride your eBike more than the time indicated, perform maintenance more frequently than recommended. If a part malfunctions, check and service it immediately, or seek help from a qualified mechanic. If a part has worn or become damaged, replace it before the next time you ride the eBike.

Read and understand the recommendations and the recommended service schedule below

Basics

- Always store the eBike in a clean dry place to avoid rust and damage to the battery.
- If storing your battery for long periods, follow the recommendations in "Battery Storage".
- Clean the frame of the eBike with a damp cloth and mild non-corrosive cleaner. For more detailed information, refer to "Cleaning".
- Do not submerge the eBike in water as the electrical system may be damaged. Be sure to store the eBike under shelter and avoid leaving it out in the rain. For more detailed information, refer to "Storage".

▲ WARNING Water damage and corrosion are not covered under warranty.

- Ensure that the tires of the eBike are always inflated to a pressure within the recommended range printed on the tire sidewall.
- Ensure that all components of the eBike are in good working condition before each ride. For more detailed information, refer to "Before Every Ride".
- Service the eBike at regular intervals. For more detailed information, refer to "Recommended Service Schedule".

- ▲ CAUTION**
 - Storage at temperatures above 77°F (25°C) can decrease battery health and overall lifespan.
 - Improper storage and/or long-term neglect of the battery can cause decreased capacity, defects, and may void the battery warranty.
 - Do not open the battery housing. Otherwise, it can result in damage to the battery or cause serious injury and/or death, and voids the warranty.

Recommended Service Schedule

Weekly Inspection

- Inspect the fasteners for proper torque.
- Inspect the drivetrain for proper alignment and function (including chain, cassette, chainset, and derailleur).
- Inspect the wheel trueness and inspect for quiet wheel operation on (without spoke noise).
- Inspect the condition of frame and its welds for damage.
- Inspect and test the brake pads.
- Inspect the tire pressure.
- Clean the frame with damp cloth and mild soap as needed.
- Clean and lubricate the chain.
- Turn barrel adjuster(s) to tighten the derailleur/brake cables if needed.
- Replace any worn or damaged components.

Monthly Inspection

- Inspect the brake pad alignment and brake cable tension.
- Inspect the shifting.
- Inspect the chain stretch.
- Inspect the brake and shifter cables for corrosion or fraying.
- Inspect the rims and check spoke tension.

- Tighten any attached the accessories (i.e. fenders, racks, reflectors) that may interfere with spokes or the drivetrain.
- Lubricate the suspension fork and brakes.
- Clean and lubricate the drivetrain.
- Clean the brake and shift cables.
- True and tension wheels if any loose spokes are identified.
- Replace the brake and shift cables if necessary.
- Replace the brake pads if necessary. Clean the brake and shift cables.
- True and tension wheels if any loose spokes are identified.

Every 6 Months Inspection

- Inspect the drivetrain (chain, chainset, cassette, and derailleur).
- Inspect all cables and housings.
- Standard tune-up by a qualified mechanic is recommended.
- Grease the bottom bracket.
- Replace the brake pads if worn.
- Replace the tires if worn.
- Replace the cables and housings if necessary.

Storage

General Storage

- Remove the battery from the eBike for long-term storage. For more detailed information, refer to “Battery Storage”.
- Keep the eBike stored in a clean, dry, and ventilated environment with an ambient temperature of 50°F to 77°F (10°C to 25°C).
- Keep the eBike stored indoors protected from direct sunlight, high temperature, and water.
- Ensure that the eBike is properly locked up to reduce risk of theft.

- ▲ CAUTION**
- Snow, rain, road salts, and acids can cause certain parts of the eBike to corrode or deteriorate.
 - Ultraviolet light from the sun can fade the paint and can cause rubber or plastic parts to become porous or to crack.
 - Exposure to excessively high or low temperatures during storage can cause temporary malfunctions or even permanent defects.
 - Storing your eBike in direct sunlight can cause damage to the display.
 - Water damage and corrosion are not covered under warranty.

Winter Storage

When winter weather strikes and temperatures plummet, you need to take a few extra precautions to ensure that your eBike is properly protected from the elements. To keep your eBike and battery safe during the winter, keep in mind:

Velotric batteries have Low Temperature Protection Mode.

When the ambient temperature is below 32°F (0°C), your Velotric eBike battery will go into Low Temperature Protection Mode, and the battery will no longer charge. This keeps your battery safe even in below-freezing temperatures.

To exit Low Temperature Protection Mode, keep your battery in a warm environment for at least 1 hour. This mode will be off when the battery temperature reaches 50°F (10°C).

Battery Storage

The eBike battery is the most sensitive component of an eBike and requires additional caution when it comes to storage. Follow the instructions below to maintain the health and longevity of the battery.

- Keep the battery away from water, corrosive materials, and heat sources.
- Do not store the battery with the charger connected or on the eBike.
- Keep the battery stored in a clean, dry, and ventilated environment with an ambient temperature of 50°F to 77°F (10°C to 25°C).
- Keep the battery out of the reach of children and animals.
- Do not lean on, stack anything on top of, or hang anything from the battery.
- Do not expose the battery or battery charger to harsh chemicals or vapors.

▲ WARNING Overheating of the battery could result in electrical fires or explosions. Always store the battery and charger in a well-ventilated area at moderate temperatures.

- Check regularly and keep the battery charged at a capacity of 60% to 80% during long-term storage.
- Recharge the battery when its capacity has dropped below 60%.
- Disconnect and remove the battery from the eBike and place it in a flat and dry place for long-term storage.
- With dielectric oil applied to the connector ends to repel moisture, the risk of corrosion decreases.
- Do not expose the battery or the charger to shocks such as falling.
- Do not store the battery upside down.

Cleaning

- Wipe any dirty painted or plastic parts with a soft, damp cloth and neutral cleaners. Carefully dry the parts with a clean, soft, and dry cloth after cleaning.
- Wipe the surface of the display with a soft cloth dampened with clean water. Do not use any cleaners or spray liquids on the surface of the display.

- ▲ CAUTION**
- Do not wash your eBike with water, as water may enter the electrical system, resulting in personal injury or malfunction of the eBike.
 - Do not grease or use a greasy cloth to wipe down the electrical connectors, brake pads, wheels, tires, or plastic parts.
 - Do not use a pressure washer as this can force water into the electrical components.
 - Do not use harsh cleaners to wash the components, which may cause materials to deteriorate, change color, distort, scratch, and so on.

Parking

The eBike is heavier than bicycles without motor support and improper parking may result in tip over, serious injury or death. Follow the instructions below when parking the eBike.

- Park in accordance with local rules and regulations, especially in a public place.
- Park indoors whenever possible. If you have to park outdoors, do not leave the eBike unsheltered in rainy or wet conditions for an extended period of time and move the eBike to a dry place soon afterwards until it dries out. When any eBike is exposed to wet conditions, a more frequent maintenance schedule is needed to prevent rust and corrosion and to ensure all systems work safely.
- Avoid parking or storing your eBike in direct sunlight, which can cause damage to the display.
- Do not park or store your eBike in excessive heat, such as inside a parked car on a hot day. Always store your eBike within this temperature range: -4°F to 140°F (-20°C to 60°C).
- Switch the power and any lights off to save battery power. Remove the key from the eBike and ensure the battery is locked to the frame or use the key to remove the battery and keep it safe.
- Park the eBike where an electric socket is available, if possible.
- Keep the eBike parked in a safe area away from children, animals, and vehicles.
- Keep the eBike parked on a level surface so it won't tip over.
- Keep the eBike away from water, corrosive materials, and heat sources.

SPECIFICATIONS

Electronic	90
Mechanical	91
Range/Speed/Weights	92

Electronic

Model	Velotric Summit 1
Motor Hub	48V, 750W, 90Nm
Battery	48V, 705.6Wh, IPX7, Certificated by UL2271
Cell	Samsung/LG 21700 cell, Certificated by UL2580
Charger	48V, 3A, Fast Charger UL Certified, operates on 100V-240V AC power outlets
Controller	48V, FOC, Max speed: 20 MPH
Sensor	Torque sensor
Display	2.8" Full color, High brightness, Bluetooth, Adjustable angle
Security	Apple Find My™
Front Light	12V/5W 130Lux high-output integrated LED, Adjustable angle
Rear Light	Brake highlight
Pedal Assist	5 Levels
Throttle Assist	Trigger-control, removable
Water Resistant	IPX6

Mechanical

Model	Velotric Summit 1
Brake Calipers	SHIMANO Hydraulic Disc Brake
Brake Levers	Aluminum Alloy, with power cutoff
Brake Rotors	180mm front and rear
Derailleur	SHIMANO 8-speed
Chain	8-speed
Frame	Aluminum alloy
Fork	Hydraulic suspension 120mm travel with Lock-out, 15x110mm thru-axle
Tires	27.5x2.6" MTB tires
Grips	Velotric sport grips, lockable
Handlebar	Aluminum Alloy, Φ 31.8mm, 700mm (Regular), 720mm (Large)
Stem	Aluminum Alloy, ϕ 31.8mm, 35mm (Regular), 50mm (Large)
Pedals	Aluminum alloy

Range/Speed/Weights

Model	Velotric Summit 1
Range	70 Miles
Max. Speed for Pedal Assisted	20 mph, Class 2
Max. Load	440 lbs
Weights	62lbs

SUPPORT INFO

Support Info

For additional support, contact the Velotric technical support team through help@velotricbike.com. Please include the following information when contacting Velotric.

- Owner name
- Contact information
- Order number
- Purchase channel
- Product model
- Frame number (bottom bracket)

WARRANTY POLICY

Limited Warranty Terms	96
This Limited Warranty Does Not Cover	96

Limited Warranty Terms

All Velopower, Inc. eBikes (the “eBike”), and their individual Covered Components (as defined herein), are protected against all manufacturing defects in material or workmanship for two (2) year after receipt of the eBike by the customer (the “Warranty Period”). This Limited Warranty is only applicable to United States eBike purchases (purchases in Canada and the European Union shall be subject to their respective warranty terms) and in accordance with the following terms:

- Only the first owner (original purchaser) of an eBike purchased from Velopower, Inc.’s online or physical storefront is covered by this Limited Warranty. Please note that bikes purchased from authorized dealers are covered by the warranty provided by the respective dealer. The Warranty Period begins upon your receipt of the eBike and shall end immediately upon the end of the Warranty Period or any sale or transfer of the eBike to another person, and under no circumstances shall the Limited Warranty apply to any subsequent owner or other transferee of the eBike.
- The Limited Warranty is expressly limited to the replacement of a defective lithium ion battery (the “Battery”), frame, forks, motor, motor controller, display, throttle, brake, front light, rear light and charger (each a “Covered Component”).
- The Covered Components are warranted defect-free in materials and/or workmanship during their respective Warranty Periods as detailed in the official website’s Warranty Policy.

▲ Notice Velopower, Inc. will revise our warranty terms in response to market performance and user requirements. Please refer to the most current warranty information available on our website. (<https://www.velotricbike.com/pages/warranty>).

This Limited Warranty Does Not Cover

- Normal wear and tear of any Covered Component (as mentioned above).
- Consumables or normal wear and tear parts (including without limitation tires, tubes, brake pads, cables and housing, grips, chain and spokes).

- Any damage or defects to Covered Components resulting from failure to follow instructions in the ebike owner’s manual, acts of God, accident, misuse, neglect, abuse, commercial use, alterations, modification, improper assembly, installation of parts or accessories not originally intended or compatible with the ebike as sold, operator error, water damage, extreme riding, stunt riding, or improper maintenance.
- For the avoidance of doubt, Velopower, Inc. will not be liable and/or responsible for any damage caused by use, speed unlock, hardware or software modifications, failure or loss caused by any unauthorized service or use of unauthorized parts.
- The Battery is not warranted from damage resulting from power surges, use of an improper charger, improper maintenance or other such misuse, normal wear or water damage.
- Any products sold by Velopower, Inc. that is not an ebike.
- Damage to a Covered Component during shipping is not covered by this Limited Warranty.

DETERMINING WHETHER DAMAGE OR DEFECT TO AN EBIKE OR COVERED COMPONENT IS PROTECTED BY THIS LIMITED WARRANTY SHALL BE IN THE SOLE DISCRETION OF VELOPOWER, INC.



Please scan the QR code to join the Facebook group.

Or visit:

facebook.com/groups/548557370182864

VELOTRIC

Contact

Website: www.velotricbike.com

E-mail: help@velotricbike.com

